

Synthesized Function Generator

數位合成信號函數波產生器

FG-109



INSTRUCTION MANUAL

使用說明書

TABLE OF CONTENTS

| | |
|------------------------------|----|
| Safety Precautions----- | 4 |
| Features----- | 5 |
| Specifications----- | 6 |
| LCD Display----- | 7 |
| Front Panel Description----- | 8 |
| Rear Panel Description----- | 10 |
| Operation Instruction----- | 11 |
| Maintenance----- | 18 |

目 次

| | |
|-------------|----|
| 一般安全概述----- | 21 |
| 特性----- | 22 |
| 規格----- | 23 |
| LCD 顯示----- | 24 |
| 前面版說明----- | 25 |
| 後面版說明----- | 27 |
| 操作說明----- | 28 |
| 維護----- | 34 |

FG-109

Synthesized Function Generator

Safety Precautions:



WARNING:

Normal usage of the equipment exposes you to a certain amount of danger from electrical shock. Because testing must sometimes be performed where exposed voltage is present. A voltage as low as 35V DC or ACrms should be considered dangerous and hazardous. You will significantly reduce the risk factor if you know and observe the following safety precaution.

- (1) Don't expose to high voltage needlessly. Remove housing and covers only when necessary.
- (2) If possible, familiarize yourself with the equipment being tested and the location of its high voltage points. However remember that high voltage may appear at unexpected points in defective equipment.
- (3) Use an insulated floor material or a large insulated floor to stand on, and use an insulated work surface on which to place equipment. Make certain such surface is not damp or wet.
- (4) Use the time proven "one hand in the pocket" technique while handling an instrument probe. Be particularly careful to avoid contacting metal objects which could be a good ground for return path.
- (5) On the AC power equipment. Remember that AC line voltage is usually present on some power input circuits, such as on-off switch, fuse, and power transformer, at any time the equipment is connected to an AC outlet, even if the equipment is turned off.
- (6) On test instruments with 3-wire AC power plugs, use only a 3-wire outlet. This is a safety feature to keep the housing or other exposed elements at earth ground.

Features:

- FG-109 is a function generator with a high resolution of 10MHz DDS.
- Various output waveforms: Sine, Square, Triangle, Pulse, Anti-Pulse.
- Variable DC offset control : $\pm 10V$ (no load).
- Store / Recall. 20 settings
- Counter up to 60MHz high frequency.
- AM with internal and external carry.
- Sweep mode with Linear and Log slope.
- FM wide modulation range up to 10 times.
- The signal Attenuate can be -20dB or -40dB.
- USB terminal for computer operation.
- LCD Display

Specifications:

| | | |
|-----------------------------|-------------------------|---|
| Main | Output Wave Form | Sine, Square, Triangle, Pulse, Anti-Pulse |
| | Amplitude Range | 10Vpp(50Ω Load) |
| | Impedance | 50Ω±10% |
| | Attenuator | -40dB |
| | DC Offset | -5~+5V(50Ω Load) |
| | Duty Range | 20%~80%, ~3MHz (Square Wave) |
| | Duty Resolution | 1% |
| | Display | 128x64 pixel LCD |
| Frequency | Sine Wave Range | 0.3Hz~10MHz |
| | Square Wave Range | 0.1Hz~3MHz |
| | Triangle Wave Range | 0.3Hz~3MHz |
| | Pulse Wave Range | 0.1Hz~1MHz |
| | Anti-Pulse Wave Range | 0.1Hz~1MHz |
| | Resolution | 0.1Hz |
| | Accuracy | 0.5% |
| Sweep | Sweep Rate | Max Rate 2:1 |
| | Sweep Time | 500uS~4S |
| | Sweep Mode | Linear, Logarithmic |
| Amplitude Modulation | Depth | 0~100% |
| | Frequency | 1KHz(internal), DC~1MHz(external) |
| | Carrier BW | 100Hz~3MHz |
| Frequency Modulation | Frequency | 1KHz |
| Counter | Range | 5Hz~60MHz |
| Memory Space | 20 sets of memories | |
| Power Source | AC115/230V±10%, 50/60Hz | |

LCD Display:

0123456789.

Displays the output waveform frequency value, counter input frequency value and duty cycle percentage.

AM EXAM

Displays AM or external amplitude modulation mode on/off state.

FM

Displays FM mode on/off state.

Sweep line Sweep log

Displays sweep mode on/off state.

Count

Displays counter mode on/off state.

Store

Displays store mode on/off state.

Recall

Displays recall mode on/off state.

Duty

Displays duty cycle adjustment mode on/off state.

-20dB

Displays amplitude -20dB mode on/off state.

Shift

Displays shift mode on/off state.

Hz KHz MHz

Displays waveform frequency and counter frequency unit.

S mS uS nS

Displays counter period unit.

%

Displays duty cycle percentage unit.



Displays the output wave form.

Front Panel Description:

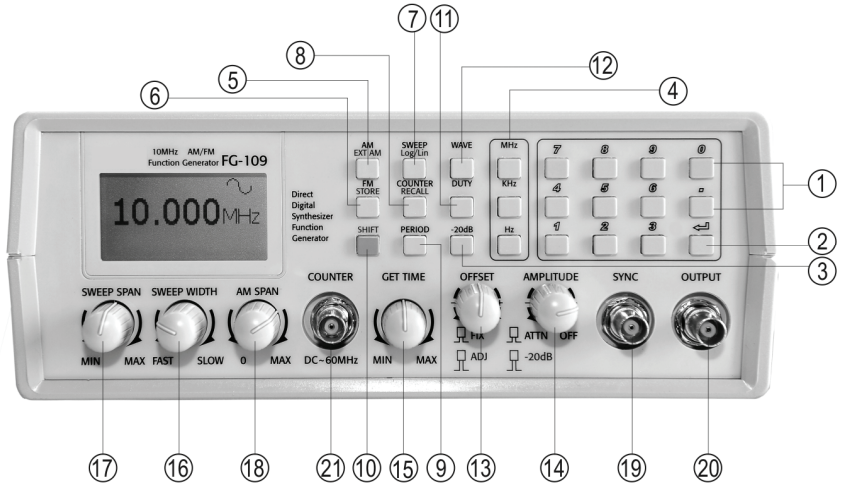

Control/Indicator Description:

① 0~9:

Enter frequency numbers. If the number is more than six-digit, it will hide all digits but only keep the last digit number.

② **ENTER:** Execute the user command.

③ **-20dB:** Switch amplitude -20dB mode on/off.

④ **Hz/KHZ/MHz:** The unit of the Set frequency value.

⑤ **AM:** Switch amplitude modulation mode on/off.

⑥ **FM:** Switch frequency modulation mode on/off.

⑦ **SWEEP:** Switch sweep mode on/off.

⑧ **COUNTER:** Switch counter mode on/off.

⑨ **PERIOD:**

When counter mode is enabled, Period key can switch frequency/period mode.

| | |
|---|---|
| ⑩ | <p>SHIFT: Set shift mode on/off.</p> <p>SHIFT + AM: Switch external/internal carry signal amplitude modulation mode.</p> <p>SHIFT + FM: Start store setting mode.</p> <p>SHIFT + SWEEP: Change sweep span curve slope between linear and log.</p> <p>SHIFT + COUNTER: Start recall setting mode.</p> |
| ⑪ | <p>DUTY: Switch square wave duty cycle adjustment mode on/off.</p> |
| ⑫ | <p>WAVE: Select output waveform.</p> |
| ⑬ | <p>OFFSET:</p> <p>When pulled out, adjusts output wave form DC offset level. The range is +5V~-5V, 50Ω load.</p> |
| ⑭ | <p>AMPL:</p> <p>Adjusting wave form amplitude. When pulled out, attenuate the wave form amplitude -20dB, this -20dB amplitude can be used with -20dB key at the same time.</p> |
| ⑮ | <p>GET TIME: Change counter gets time range.</p> |
| ⑯ | <p>SWEEP WIDTH:</p> <p>Change sweep time between start frequency and end frequency.</p> |
| ⑰ | <p>SWEEP SPAN:</p> <p>Change sweep slope between start frequency and end frequency.</p> |
| ⑱ | <p>AM SPAN:</p> <p>Change the depth of amplitude modulation.</p> |
| ⑲ | <p>SYNC:</p> <p>Output TTL wave form. The terminal is 50Ω impedance.</p> |
| ⑳ | <p>OUTPUT:</p> <p>Output Function wave form. The terminal is 50Ω impedance.</p> |
| ㉑ | <p>COUNTER: Counter signal input.</p> |

Rear Panel Description:

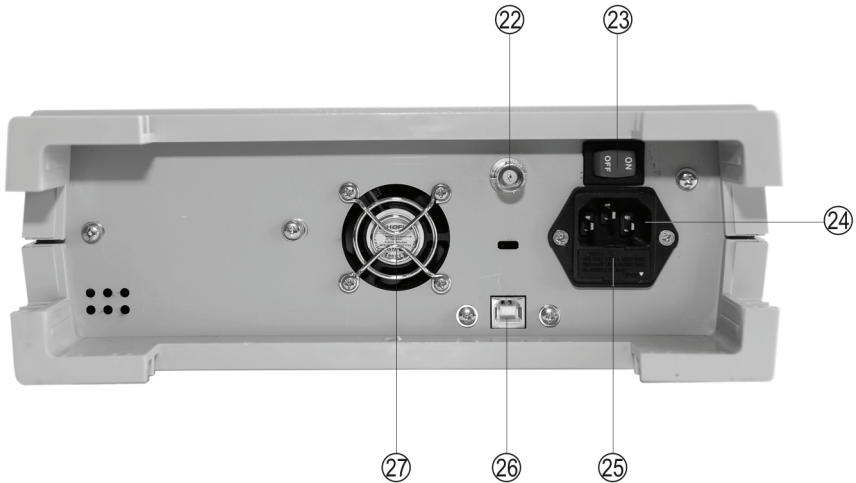

Control/Indicator Description:

②② **EXT AM:** Input external carry signal to amplitude modulation.

②③ **POWER SWITCH:** On/Off for the power up sequence.

②④ **AC POWER INPUT:**

Accept the AC power cord. 115/230V $\pm 10\%$, 50/60Hz.

②⑤ **FUSE HOLDERR / AC VOLTAGE SELECTOR:**

Sects 115V or 230V for power source. Refer to the Arrow marks on the fuse plug and the mark on the panel.

②⑥ **USB INPUT TERMINAL:** USB connector for Computer operation.

②⑦ **Ventilation Fan:** 40mm DC Fan for cooling purpose.

Operating Instructions:



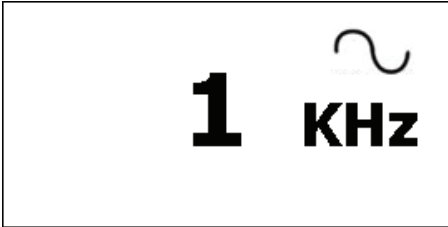

NOTE:

Before applying power to the unit. Make sure that input voltages setting id correct and the ventilation holes are not blocked.

1. Function Wave Output:



(1) Wave Select: Press **WAVE** (12) key and wave icon will show on monitor in circle.

| | |
|---|---|
|  | Sine wave output, sine wave output frequency limit is 10MHz. |
|  | Triangle wave output, triangle wave output frequency limit is 3MHz. |
|  | Square wave output, square wave output frequency limit is 3MHz. |
|  | Pulse wave output, pulse wave output frequency limit is 1MHz. |
|  | Anti-pulse wave output, anti-pulse wave output frequency limit is 1MHz. |

(2) Unit Select: Press **Hz/KHz/MHz** (4) output function wave will change the frequency as selected.

2. Square Wave Duty Cycle Adjustment:



When setting Square wave output, pressing the **DUTY**(11) key will enter duty cycle adjustment mode. Press number key to set duty cycle percentage, ranges between 20~80%. After setting the value, press **Enter**(2) to execute duty cycle adjustment.

3. Amplitude -20dB:

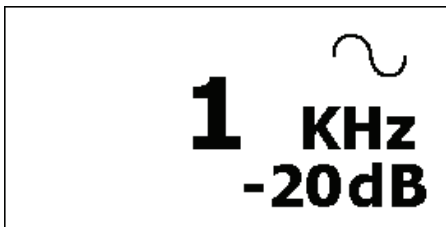

-20dB Switch: Press **-20dB**(3) key and output amplitude decay 20dB(10 times). Press **-20dB**(3) key again to change back.

4. Amplitude Modulation:

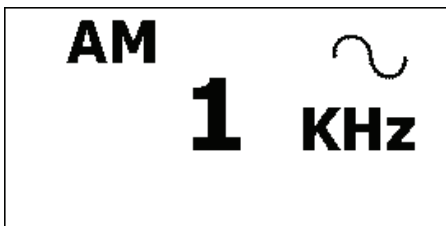

- (1) Enable AM: Press **AM**(5) key and waveform will set to sine wave automatically. FG-109 modulating with internal 1KHz sine wave.
- (2) AM SPAN: Turn the knob (18) to change AM depth. Range of 0~100%.

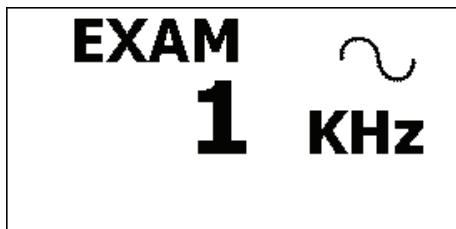

- (3) Enable EXAM: Press **SHIFT**(10) key then press **AM**(5) key will enter external amplitude modulation mode. In this mode, FG-109 will modulate with external carry signal from **EXT-AM**(22) connector.

5. FM Modulation:

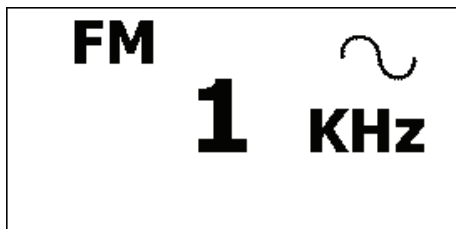

- (1) Enable FM: Press **FM**(6) key and waveform will set to sine wave automatically. FG-109 modulating with internal 1KHz sine wave. Frequency modulation range is 50%~1000%, center frequency is current setting frequency.
- (2) Sweep Width: Turn the knob (16) and change each frequency level's interval time. Range is 500uS~4S.

6. Sweep Function:



- (1) Enable Sweep: Press **SWEEP** (7) key and waveform will set to sine wave automatically. Default slope form is linear slope.



- (2) Slope Switch: In sweep mode, press **SHIFT** (10) key then press **SWEEP** (7) key will switch sweep slope form between linear slope and log slope.
- (3) Sweep Span: Turn the knob (17) and change end frequency ratio from 10% ~200%.
- (4) Sweep Width: Turn the knob (16) and change each frequency level's interval time from 500uS~4S.

7. Counter Function:



- (1) Enable Counter: Press **COUNT**Ⓢ key, FG-109 changes to counter mode. Default display unit is frequency.

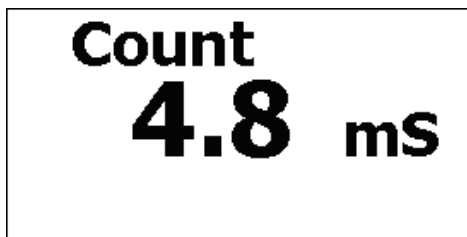

- (2) Period Switch: In counter mode, press **PERIOD**Ⓣ key and LCD display unit changes to period. Press **PERIOD**Ⓣ again will change the display unit back.
- (3) Get Time: Turn the knob Ⓣ and change counter get time from 500uS to 1S.

8. Store and Recall Function:

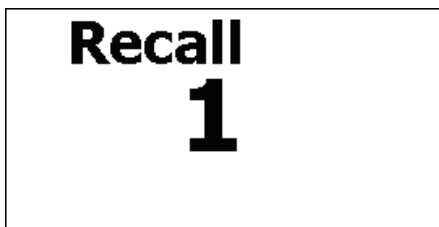

- (1) Store: Press **SHIFT**Ⓛ key then press **FM**Ⓜ key, FG-109 will enable store current setting mode. FG-109 can store 20 sets.
- (2) Recall: Press **SHIFT**Ⓛ key then press **COUNTER**Ⓢ key, FG-109 will enable recall setting mode.

9. USB Operation.

(1) Install USB driver.

Input "USB" folder in CD.

(A) If the computer system is Windows 7, please install "CP210x_VCP_Win7.exe".

(B) If the computer system id Windows XP, 2000 or Vista, please install "CP210x_VCP_Win2K_XP_2K3.exe".

(2) Install FG-109 application program

(A) Enter "Application" folder in CD.

(B) Install "setup.exe".

(3) Stare application program.

(A) Execute application program. The computer will display as below.

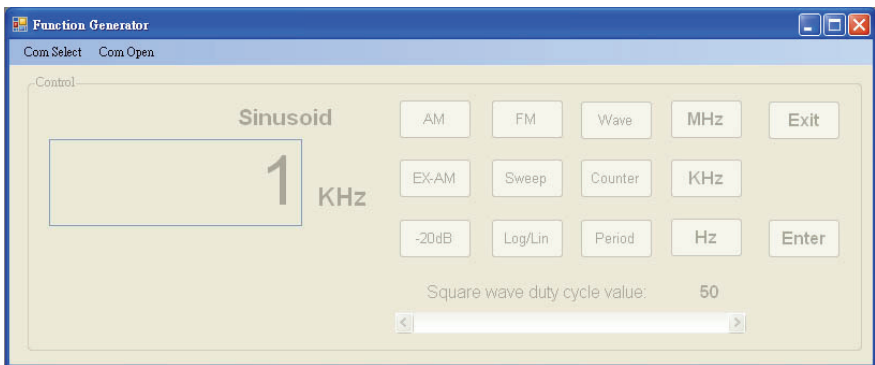

(B) Click "Com Select" to select COM port. If more then one COM port is listed, please select largest COM port.

(C) Select " Com Open" to open COM port communication function.

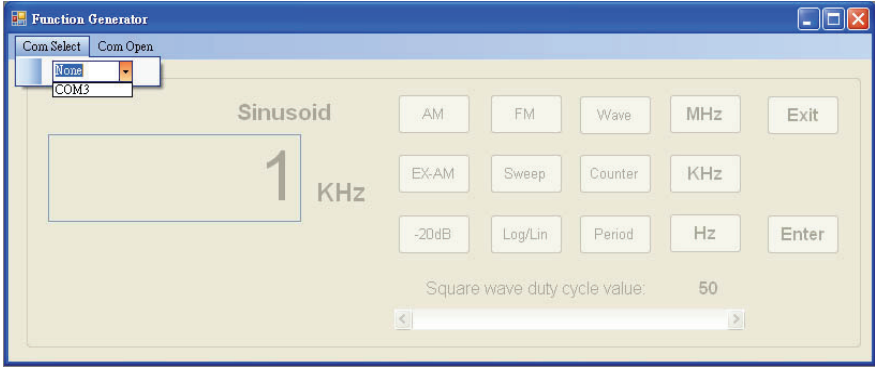

(D) After COM port open. The computer will display as below and user can control FG-109 full function be computer.

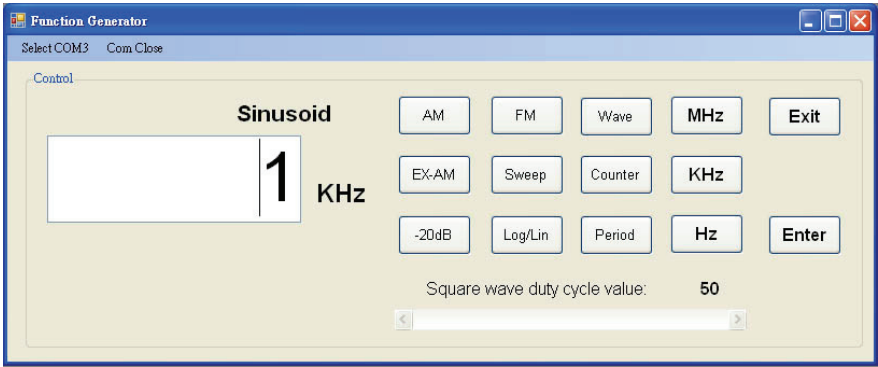

Maintenance:

1. Preventive Maintenance:

Please follow the following preventives steps to ensure the proper operation of your instrument.

- (1) Never place a hot soldering iron on or near the instrument.
- (2) Never insert wires, pins or other metal object into the ventilation fan.
- (3) Never move or pull the instrument with the power cord or output lead. Specifically, never move instrument when the power cord or output lead is connected.
- (4) Do not obstruct the ventilation holes in the rear panel as this will increase the internal temperature.
- (5) Do not operate the instrument with the cover removed, unless you are a qualified service technician.
- (6) Clean and check the calibration of the instrument on a regular basis to keep the instrument looking nice and working well.
- (7) Never place heavy objects on the instrument.

2. Fuse Replacement:

If the fuse blows, the LCD will not light and the instrument will not operate.

Replace only with the correct value fuse. The fuse is located on the rear panel adjacent to the power cord receptacle.

- (1) Remove the fuse holder assembly as follows:
 - (a) Unplug the power cord from rear of the instrument.
 - (b) Insert a small screwdriver in the fuse holder slot (located between fuse holder and receptacle). Pry fuse holder away from receptacle.
 - (c) When reinstalling fuse holder, be sure that the fuse is installed so that the correct line voltage is selected.

NOTE:

When re-inserting the fuse holder, be sure that the fuse is installed so

that the correct line voltage can be selected.

3. Service Information.

Some of common problems that may occur and remedy to put back the instrument in a working condition as fast as possible are given below,

When the unit is not turning ON:

Check if power On/Off switch is turned ON. If not, then check the power cord. Please make sure that the power cord is properly connected to the unit. Please also check the main switch. And ensure that the AC supply at your site is the same as the one mentioned at the rear chassis of the unit. For further help call the service personnel.

4. Cleaning.

Remove any dirt, dust and grime whenever they become noticeable. Clean the outside cover with a soft cloth moistened with a mild cleaning solution.

FG-109

數位合成信號函數波產生器

一般安全概述:



日常生活中使用任何的電器產品都有可能會有觸電的危險。根據醫學報導，只要10mA的電流通過心臟，都有可能造成生命的危險。因此，我們將35V DC或35 V AC rms 以上都視為危險電壓，如使用不當都會影響生命安全。因此，請特別注意下列事項，以確保您自身的安全。

- (1) 非必要時，請避免靠近高壓電源，只在需要使用時才能將高壓電的遮蔽蓋打開。測試高壓電路前，也必須先將電源切斷，待測試棒接受後，再打開電源。如果有高壓電容，在測試中會充電，因此斷電後，也須另外進行放電步驟。
- (2) 儘可能先熟悉設備中高壓電的位置，這是避免觸電的方法之一，但是在故障的設備中，高壓電可能會亂竄，因此任何地方都有危險性。
- (3) 修理設備時，請在絕緣地板上或是有大塊面積的絕緣材料上工作，並注意是否潮濕或破損。
- (4) 在測量電路時，請習慣用單手操作，另一隻手請放在口袋中且勿接觸機器本身或其它導體，這樣可以避免電流通過心臟。
- (5) 使用 AC 電源設備時，更應注意自身的安全保護。因為 AC 電源會隨著導體電線等傳遞，就算將電源開關撥到 OFF，某些地方仍然會帶電，如變壓器、電源開關等，除非將插頭確實移開插座才能完全斷電。
- (6) 大部分的儀器設備所配用的電源線有 3 個接觸端子，其中一個端子是接地，可以避免設備的外殼帶電，但是也有一些例如家電設備等裝置只配用 2 個接觸端子的電源線，但大部分都會有塑膠外殼作為絕緣保護；當需要維修測試，必須除去塑膠外殼時，請特別注意其危險性。
- (7) 當使用3線電源插頭時，請勿將接地端拆除，因為只有將接地線牢牢接妥才能避免機殼漏電。

特性:

1. 特性:

- (1) FG-109 是一台 10MHz 高解析度數位合成信號函數波產生器。
- (2) 可輸出不同波形，正弦波，方波，三角波，脈波，反脈波。
- (3) 可變式 DC offset 控制: +/- 10V (無負載)。
- (4) 20 組儲存 / 回復功能
- (5) 計頻器可到 60MHz 高頻
- (6) 調幅模式有內建輸入的載波及外部輸入的載波。
- (7) 掃瞄斜率有線性及對數線兩種模式。
- (8) 調頻模式可達到 10 倍。
- (9) 訊號衰減可以-20dB 或-40dB。
- (10) USB 端可與電腦操作。

規格:

| | | |
|------|---------------------------|-----------------------|
| 主要輸出 | 輸出波形 | 正弦波，方波，三角波，脈波，反脈波 |
| | 振幅範圍 | 10Vpp(50Ω Load) |
| | 阻抗 | 50Ω±10% |
| | 衰減器 | -40dB |
| | 直流抵補 | -5~+5V(50Ω Load) |
| | 周期範圍 | 20%~80%，~3MHz(方波) |
| | 周期解析度 | 1% |
| | 顯示 | 128x64 pixel LCD |
| 頻率 | 正弦波範圍 | 0.3Hz~10MHz |
| | 方波範圍 | 0.1Hz~3MHz |
| | 三角波範圍 | 0.3Hz~3MHz |
| | 脈波範圍 | 0.1Hz~1MHz |
| | 反脈波範圍 | 0.1Hz~1MHz |
| | 解析度 | 0.1Hz |
| | 精確度 | 0.5% |
| 掃描 | 掃描速度 | Max Rate 2:1 |
| | 掃描時間 | 500uS~4S |
| | 掃描型態 | 線性，對數 |
| 振幅調變 | 調變深度 | 0~100% |
| | 調變頻率 | 1KHz(內建), DC~1MHz(外部) |
| | 載波頻寬 | 100Hz~3MHz |
| 頻率調變 | 調變頻率 | 1KHz |
| 記頻器 | 範圍 | 5Hz~60MHz |
| 記憶空間 | 20 組記憶 | |
| 工作電源 | AC115/230V ± 10%, 50/60Hz | |

LCD 顯示:

0123456789.:

顯示輸出波形的頻率值、計頻器輸入頻率值及責任週期百分比。

AM EXAM 振幅調變:

顯示振幅調變或外部振幅調變模式的開啓/關閉狀態。

FM 頻率調變:

顯示頻率調變模式的開啓/關閉狀態。

Sweep line Sweep log 線性掃描 對數掃描:

顯示掃描模式的開啓/關閉狀態。

Count 計頻器:

顯示計頻器模式的開啓/關閉狀態。

Store 儲存:

顯示儲存模式的開啓/關閉狀態。

Recall 回復:

顯示回復模式的開啓/關閉狀態。

Duty 工作週期:

顯示工作週期調節模式開啓/關閉狀態。

-20dB -20dB 衰減 10 倍:

顯示振幅-20dB 模式的開啓/關閉狀態。

Shift 延伸功能:

顯示延伸模式開啓/關閉狀態。

Hz KHz MHz 計頻單位:

顯示波形頻率及計頻器頻率的單位。

S mS uS nS 時間:

顯示計頻器週期單位。

% 百分比:

顯示工作週期百分比的單位。

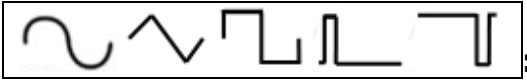

顯示輸出波形。

前面板說明:

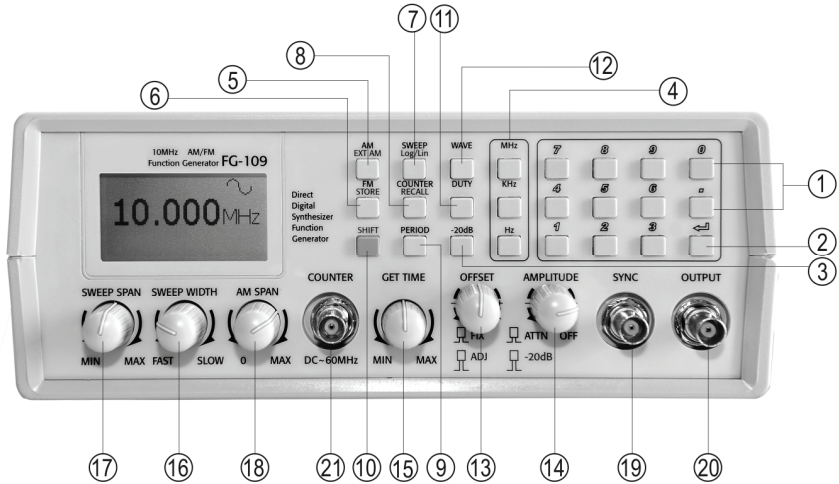

說明:

- ① **0~9:** 輸入頻率的數目。如果數目超過六位數，它將隱藏所有的數字，但只保留最後一位數字。
- ② 輸入: 執行使用者的命令。
- ③ 衰減 10 倍: 開啓/關閉振幅 -20dB 模式。
- ④ **Hz/KHz/MHz:** 頻率設定值到 hertz。
 - 計頻單位 (Hz): 設定頻率值單位為赫茲。
 - 計頻單位 (KHz): 設定頻率值單位為千赫。
 - 計頻單位 (MHz): 設定頻率值單位為百萬赫茲。

| |
|--|
| ⑤ 振幅調變: 開啓/關閉振幅調變模式。 |
| ⑥ 頻率調變: 開啓/關閉頻率調變模式。 |
| ⑦ 掃描: 開啓/關閉掃描模式。 |
| ⑧ 計頻器: 開啓/關閉計頻器模式。 |
| ⑨ 周期: 當計頻器模式啓用時, 周期鍵可以切換頻率/週期模式。 |
| ⑩ 延伸功能: 開啓/關閉延伸模式。 SHIFT + AM: 開啓/關閉外部振幅調變模式。 SHIFT + FM: 開啓儲存設置模式。 SHIFT + SWEEP: 更改線性與對數掃描跨距曲線斜率。 SHIFT + COUNTER: 啓動回復設置模式。 |
| ⑪ 工作周期: 開啓/關閉方波的工作週期調節模式。 |
| ⑫ 波形: 選擇輸出波形。 |
| ⑬ 直流抵補: 拉出後, 調整輸出波形直流偏移量程度, 範圍爲 +5V~ -5V, 50 Ω 負載。 |
| ⑭ 振幅: 調整波形振幅。拉出後, 減少波形振幅 -20dB。此 -20dB 振幅可同時跟 -20dB 鍵一起使用。 |
| ⑮ 截取時間: 更改計頻器截取時間的範圍。 |
| ⑯ 掃描時間: 更改起始頻率和終止頻率之間的掃描時間。 |
| ⑰ 掃描高度: 更改起始頻率及終止頻率之間的掃描高度。 |
| ⑱ 調幅高度: 更改振幅調變的深度。 |
| ⑲ 同步: 輸出 TTL 波形; 電極阻抗爲 50 Ω 。 |
| ⑳ 輸出: 輸出函數波形; 電極阻抗爲 50 Ω 。 |
| ㉑ 計頻器: 計頻器信號輸入 |

背板說明:

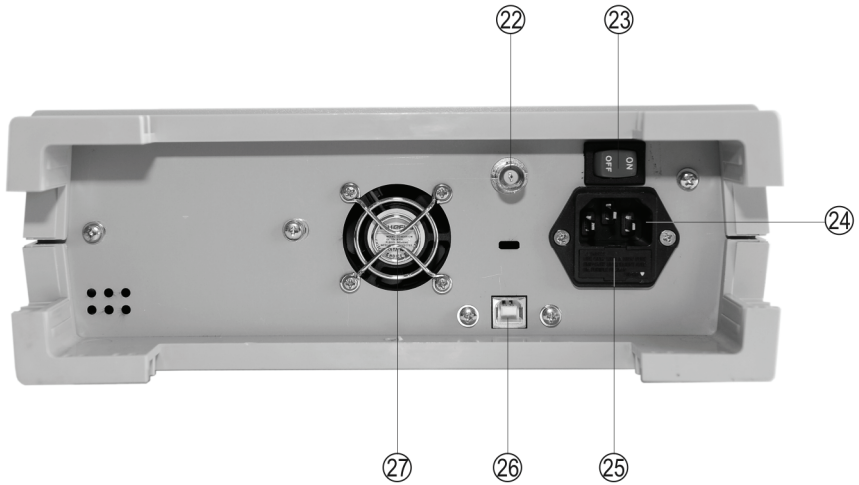

說明:

②② EXT AM:外接調幅輸入: 輸入帶有波形的外部振幅調變。

②③ 電源開關: 使用 ON/OFF 操作電源開關。

②④ AC 電源輸入: 可接受 A/C 115 或 230V, 50/60Hz 電源線。

②⑤ 保險絲座 / AC 電壓選擇: 設定 115V 或 230V 電源。請參考保險絲座上的箭頭指示。

②⑥ USB 輸入端: 與電腦連接 USB 轉接頭。

②⑦ 散熱風扇: 40mm DC 散熱風扇。

操作前注意事項:



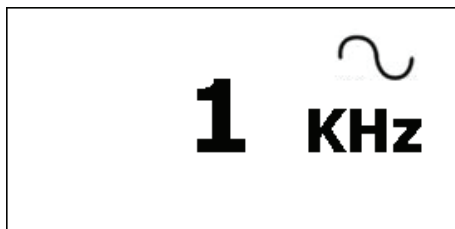

注意!

操作此產品之前, 請確定輸入電壓設定 ID 是否正確, 散熱孔不可以有堵塞。

1. 函數波形輸出:



(1) 波形選擇: 按 **WAVE**  鍵, 波形將以圖形顯示於螢幕上。

| | |
|---|---------------------------|
|  | 正弦波輸出, 正弦波輸出頻率上限為 10MHz。 |
|  | 三角波輸出, 三角波輸出頻率上限為 3MHz。 |
|  | 方波輸出, 方波輸出頻率上限為 3MHz。 |
|  | 脈衝波輸出, 脈衝波輸出頻率上限為 1MHz。 |
|  | 反脈衝波輸出, 反脈衝波輸出頻率上限為 1MHz。 |

(2) 單位選擇: 按 **Hz/KHz/MHz**  鍵, 輸出函數波將更改為選定的頻率。

2. 方波工作週期校正:



設置方波輸出時，按下 **DUTY** ① 鍵將進入工作週期校正模式。按數字鍵來設定工作週期百分比，介於 20~80% 的範圍。設置好數值後，按下 **Enter** ② 鍵執行工作週期校正。

3. 振幅 -20dB

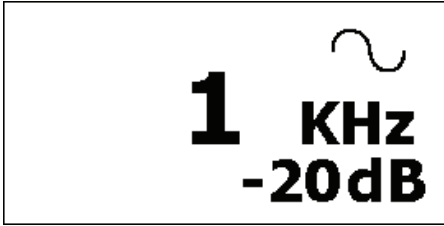

-20dB 開關：按下 **-20dB** ③ 鍵將把輸出振幅衰減 20dB(10 倍)；再按下 **-20dB** ③ 鍵將恢復回原狀。

4. 振幅調變：

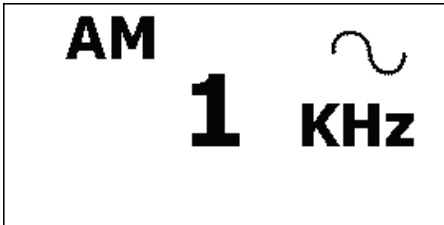

- (1) 啓動振幅調變：按下 **AM** ⑤ 鍵將自動把波形設定為正弦波。FG-109 型號內部調整為 1KHz 正弦波。
- (2) 振幅調變跨度：轉動旋鈕 ⑩ 可更改振幅調變深度。取值範圍為 0~100%。

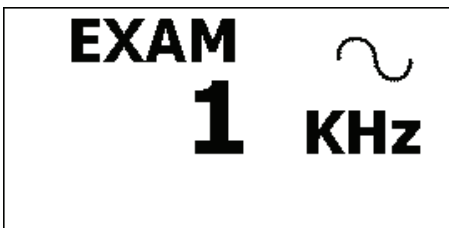

- (3) 啓動外部振幅調變：按下 **SHIFT**⑩鍵然後按下 **AM**⑤鍵將進入外部振幅調變模式。在此模式下，FG-109 將從外部振幅調變連接器 **EXT-AM**⑳調變外部信號。

5. 頻率調變：

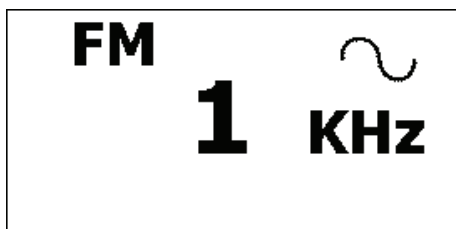

- (1) 按下 **FM**⑥鍵將自動把波形設定爲正弦波, FG-109 型號內部調整爲 1KHz 正弦波, 頻率調變範圍爲 50~100%, 中心頻率是目前的設定頻率。
- (2) 掃描時間：轉動旋鈕⑯可更改每個頻率的間隔時間, 範圍爲 500uS~4S。

6. 掃描功能：



- (1) 啓動掃描：按下 **SWEEP**⑦鍵將自動把波形設定爲正弦波, 預設的斜率爲線形斜率。



- (2) 斜率開關：在掃描模式中，按下 **SHIFT**⑩鍵再按下 **SWEEP**⑦鍵將切換掃描波形式從直線斜率到對數斜率。
- (3) 掃描跨度：轉動旋鈕⑰可變換結束頻率比從 10% 到 200%。
- (4) 掃描時間：轉動旋鈕⑱可更改每個頻率量度的間隔時間從 500uS~4S。

7. 計頻器的功能：



The image shows a rectangular LCD display with a black border. The text on the display is arranged in three lines: "Count" in a large, bold, sans-serif font at the top; "48.8" in a very large, bold, sans-serif font in the middle; and "MHz" in a large, bold, sans-serif font at the bottom right.

- (1) 啓動計頻器：按下 **COUNT**⑧按鈕將把 FG-109 改換成計頻器模式。預設顯示單位爲頻率。

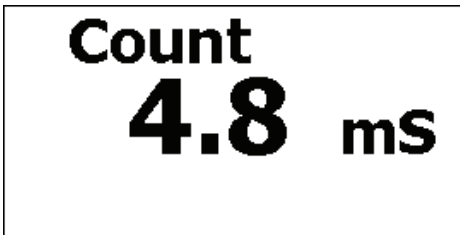

The image shows a rectangular LCD display with a black border. The text on the display is arranged in three lines: "Count" in a large, bold, sans-serif font at the top; "4.8" in a very large, bold, sans-serif font in the middle; and "ms" in a large, bold, sans-serif font at the bottom right.

- (2) 時間按鍵：在計頻器的模式下，按下 **PERIOD**⑨按鍵將把 LCD 顯示單位轉換成時間。再按一下 **PERIOD**⑨將切換回原來的顯示單位。
- (3) 截取時間：轉動旋鈕⑲將轉換計頻器的截取時間從 500uS 到 1S。

8. 儲存與回復功能

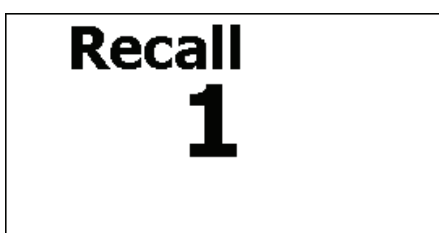

- (1) 儲存：按下 **SHIFT**⑩按鍵再按下 **FM**⑥按鍵, FG-109 將儲存當下的設置模式; FG-109 可以儲存 20 組。
- (2) 回復：按下 **SHIFT**⑩按鍵再按下 **COUNTER**⑧按鍵, FG-109 將啟動回復設置模式。

9. USB 操作:

- (1) 安裝 USB 驅動程式, 進入 CD 片內"USB"檔案夾;
 - (A) 如果電腦系統是 Window 7, 請安裝:
"CP210x_VCP_Win7.exe"
 - (B) 如果電腦系統是 Window XP, 2000 或 Vista, 請安裝:
"CP210x_VCP_Win2K_XP_2K3.exe"
- (2) 安裝 FG-109 應用程式
 - (A) 進入 CD 片內"Application" 檔案夾;
 - (B) 安裝 "setup.exe"
- (3) 開始應用程式
 - (A) 執行應用程式, 電腦會顯示以下畫面:

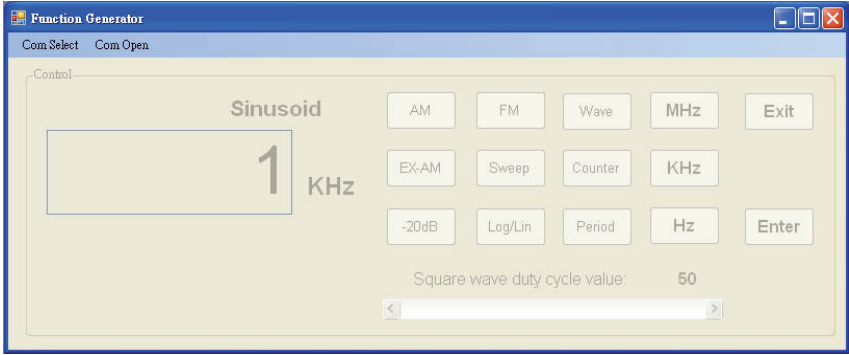

(B) 點選“Com Select”選擇要使用的 COM port, 如果電腦有超過一個 COM port, 請點選最大的 COM port。

(C) 選擇 “Com Open”開啓 COM port 通信功能。

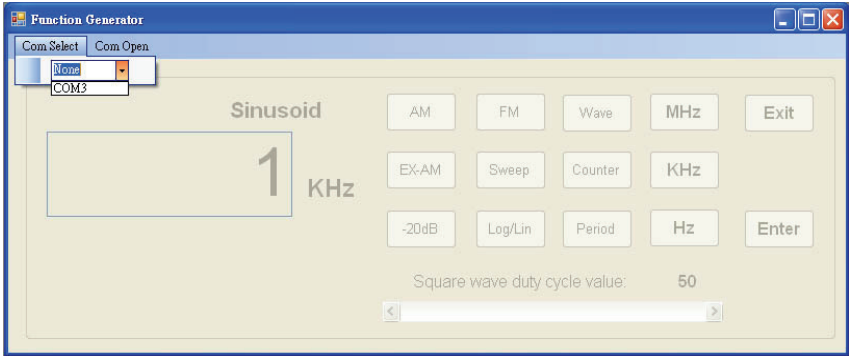

(D) 在 COM port 開啓後。電腦將會顯示以下畫面並且使用者可以開始經由電腦操作 FG-109 所有功能。

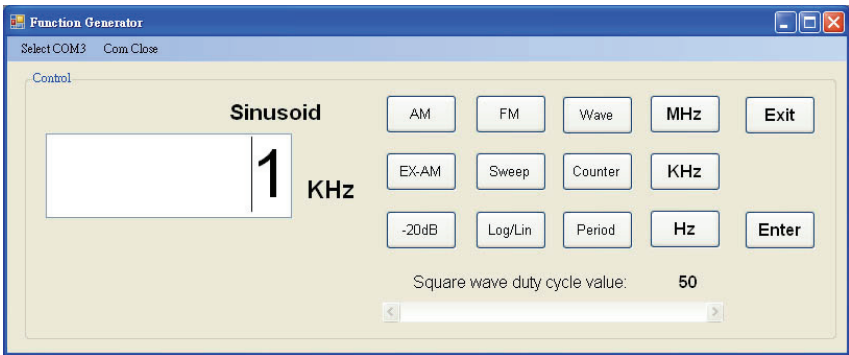

維護：

1. 有效的維護：

- (1) 請勿在機器上面放置重物。
- (2) 請勿在機器上面或附近放至發熱物體。
- (3) 請勿將任何細線或針狀物插入散熱風扇孔。
- (4) 請勿拉扯電源線或測試線來移動機器，尤其是供電狀態下。
- (5) 請勿將散熱風扇孔阻擋。
- (6) 機器使用中請勿將上蓋打開。
- (7) 請定期校正機器以保持準確性，並保持機器清潔。

2. 更換保險絲：

當機器接上電源並開機後，LCD 無法顯示時，請更換保險絲。

- (1) 移去電源線，斷開電源。
 - (2) 以小一字起子掀開保險絲座蓋(在本機電源插座上)。
 - (3) 取出舊的保險絲並換上新的正確保險絲。
 - (4) 蓋回保險絲座，重新接上電源線，開機即可。
- (如機器仍無法正常操作，請與指定之經銷商聯絡。)

註：當重新插入保險絲座，請確定保險絲是安裝在正確的電壓。

3. 維修資訊：

如有一般性的問題發生時，請依照以下方式將儀器回復到工作環境

當儀器不是在“ON”的狀態，請先確認電源 ON/OFF 是在 ON 的狀態，如果不是，請確認電源線電源線是正確的連接到產品上。

請確認主機板並確認 AC 供應端是否與產品背板所敘述的相同，如需更進一步的協助請與維修部門聯繫。

3. 清潔：

請保持機器清潔，如需清除灰塵及髒污時，請使用輕軟乾淨的布沾上微量的中性清潔液輕輕的在產品外觀擦拭。

MEMO:

MEMO:

MEMO:

TINSE0089S4 Ver.01

Made In Taiwan